

MONTAGEANLEITUNG

MOUNTING INSTRUCTIONS

INSTRUCCIONES DE MONTAGE

INSTRUCCIONES DE MONTAJE

ba75827defs02 12/2017



A 325/K

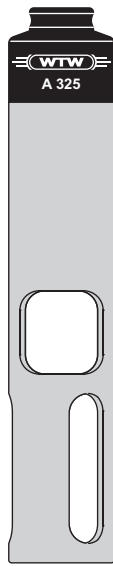

A 325/S



A 925/K



A 925/S

A 325/K, A 325/S
A 925/K, A 925/S



a xylem brand

A 325/...; A 925/...

Bedienungsanleitung	3
Montage.	5
Technische Daten	5
Weiteres Zubehör	5
Operating manual	6
Installation	8
Technical data	8
Further accessories	8
Mode d'emploi	9
Montage.	11
Caractéristiques techniques	11
Autres accessoires	11
Instrucciones de operación	12
Montaje	14
Especificaciones técnicas	14
Otros accesorios	14

Copyright © 2017 Xylem Analytics Germany GmbH
Printed in Germany.



A 325/K

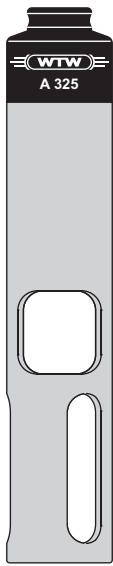

A 325/S



A 925/K

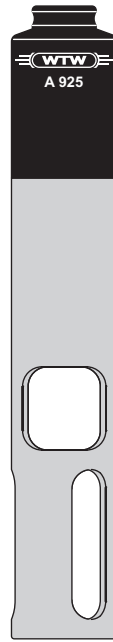

A 925/S

A 325/K, A 325/S
A 925/K, A 925/S



a xylem brand



Bild 1



Bild 2

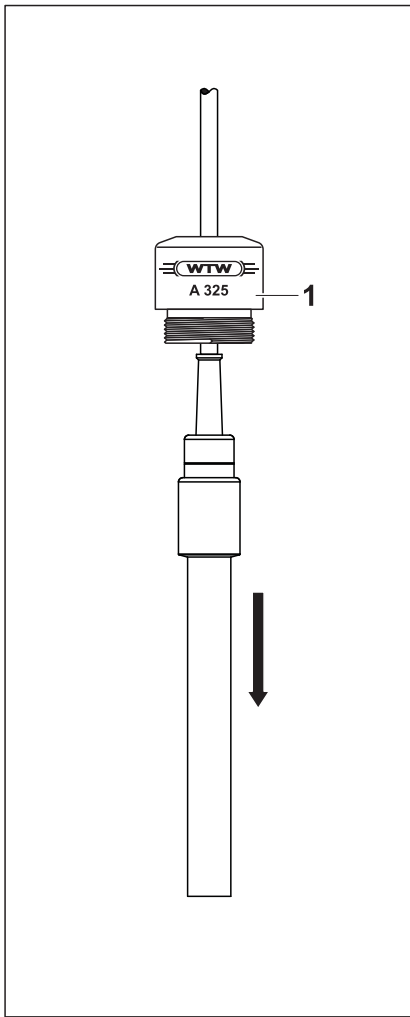

Bild 3

Montage

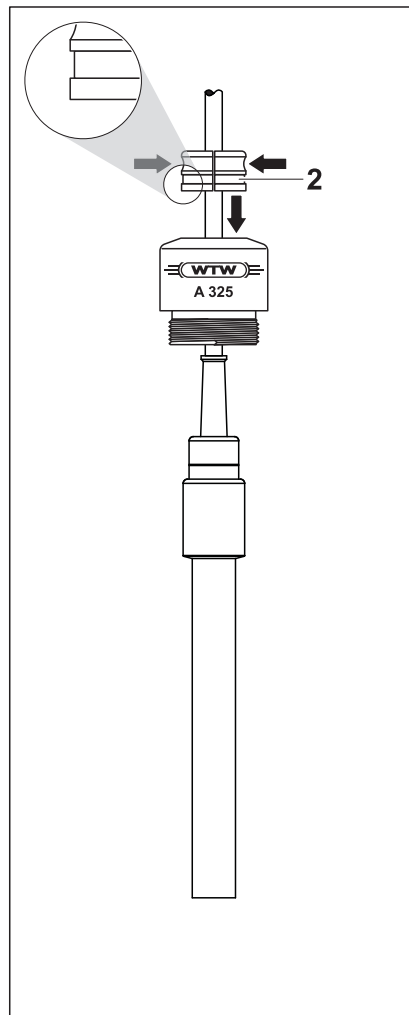
Sensoreinbau		
	1	Sensor durch Armatur (Pos. 1 in Bild 1) schieben.
	2	Klemmring (Pos. 2 in Bild 2) in Sensorkabel einhängen. Der scharfkantige Rand des Klemmrings muss in Richtung Armierung zeigen (siehe Detailbild in Bild 2).
	3	Klemmring ganz zusammendrücken (Spalt geschlossen), in Armierung einführen und durch Loslassen einrasten lassen.
	4	Sensor bis zum Anschlag in Armierung zurückschieben (Bild 3).
	5	Überwurfmutter (Pos. 3 in Bild 3) über Sensor schieben und von Hand in Armierung hineinschrauben.
	6	Schutzkorb (Pos. 4 in Bild 3) aufschrauben.

Technische Daten

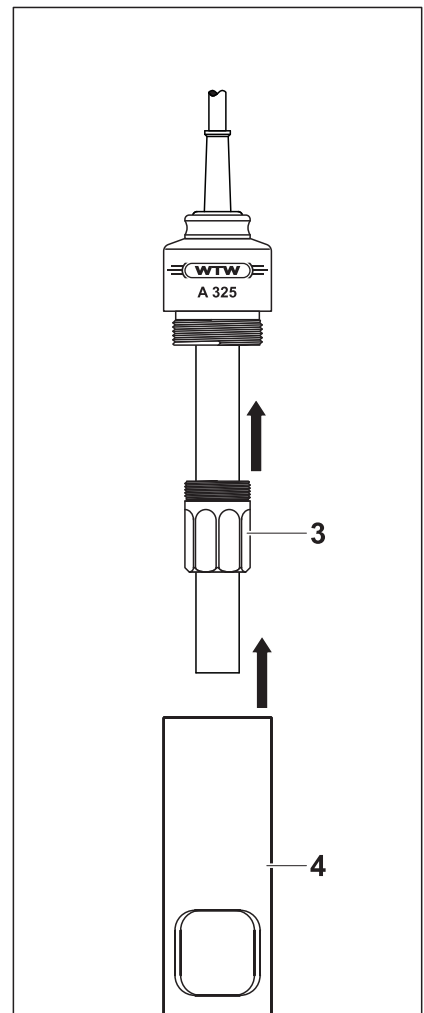
Abmessungen	Durchmesser	38 mm
	Länge (A 325/...)	200 mm
	Länge (A 925/...)	228 mm
Materialien	Armierung	POM
	Klemmring	POM
	Schutzkorb (A 325/K und A 925/K)	POM
	Schutzkorb (A 325/S und A 925/S)	Edelstahl 1.4571
	O-Ringe (nur A 325/...)	NBR

Weiteres Zubehör

Beschreibung	Modell	Best.-Nr.
Schutzdeckel für A 325/... und A 925/...	SK-325	201 580

MOUNTING INSTRUCTIONS

ba75827e02 12/2017



A 325/K

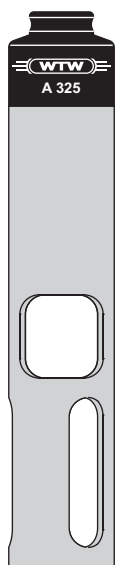

A 325/S



A 925/K

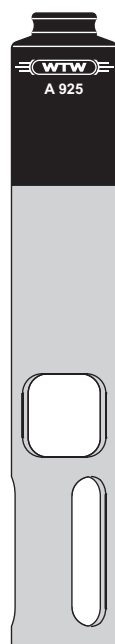

A 925/S

A 325/K, A 325/S
A 925/K, A 925/S



a xylem brand

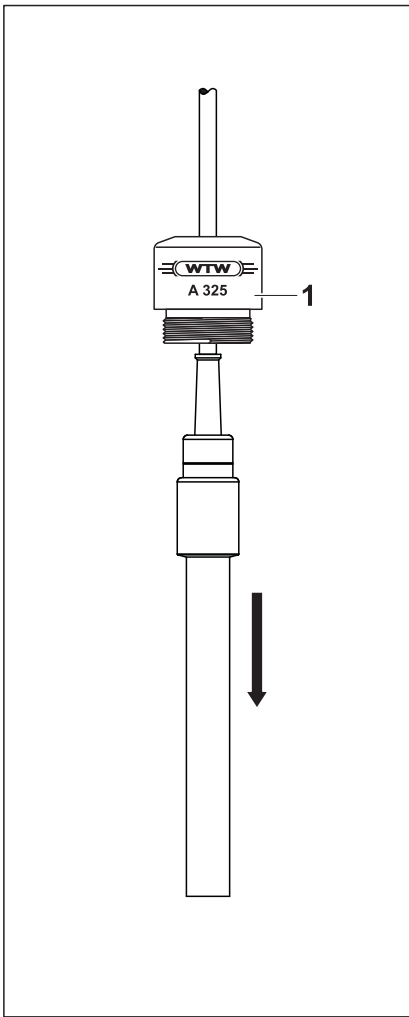

Figure 1

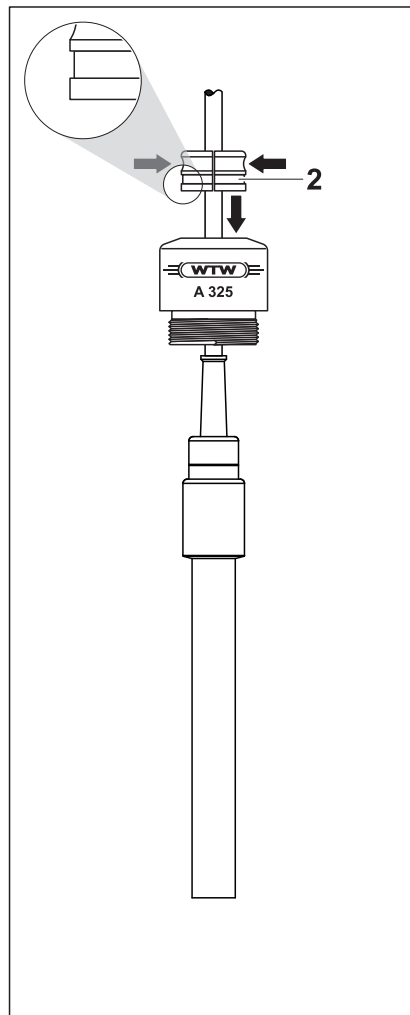

Figure 2

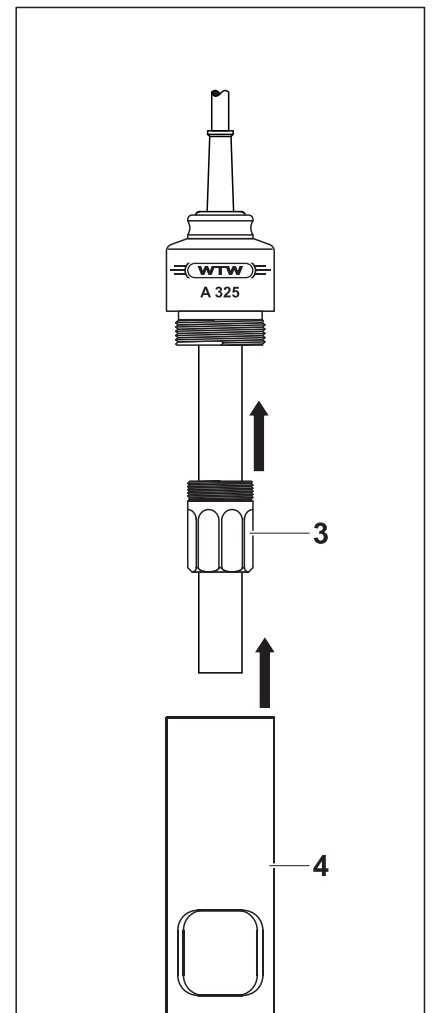

Figure 3

Installation

Installing the sensor

1	Push the sensor through the armature (pos. 1 in figure 1).
2	Clip the clamping ring (pos. 2 in figure 2) on the sensor cable. The sharp-edged side of the clamping ring should point to the armoring (see detail of figure 2).
3	Press the clamping ring together (gap closed), insert it in the armoring and release it so it clicks into place.
4	Push back the sensor into the armature as far as it will go (figure 3).
5	Slide the coupling ring (pos. 3 in figure 3) on the sensor and screw it into the armature by hand.
6	Screw on the protective hood (pos. 4 in figure 3).

Technical data

Dimensions	Diameter	38 mm
	Length (A 325/...)	200 mm
	Length (A 925/...)	228 mm
Materials	Armoring	POM
	Clamping ring	POM
	Protective hood (A 325/K and A 925/K)	POM
	Protective hood (A 325/S and A 925/S)	Stainless steel 1.4571
	O-rings (A 325/... only)	NBR

Further accessories

Description	Model	Order no.
Protective cover for A 325/... and A 925/...	SK-325	201 580

**INSTRUCTIONS
DE MONTAGE**

ba75827f02 12/2017



A 325/K

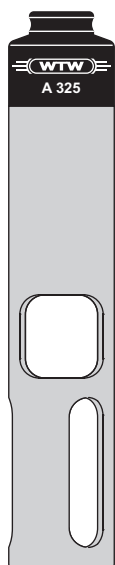

A 325/S



A 925/K

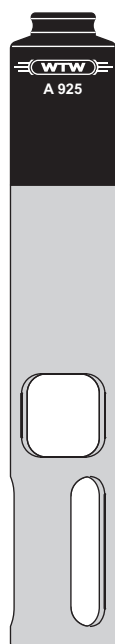

A 925/S

A 325/K, A 325/S
A 925/K, A 925/S



a xylem brand

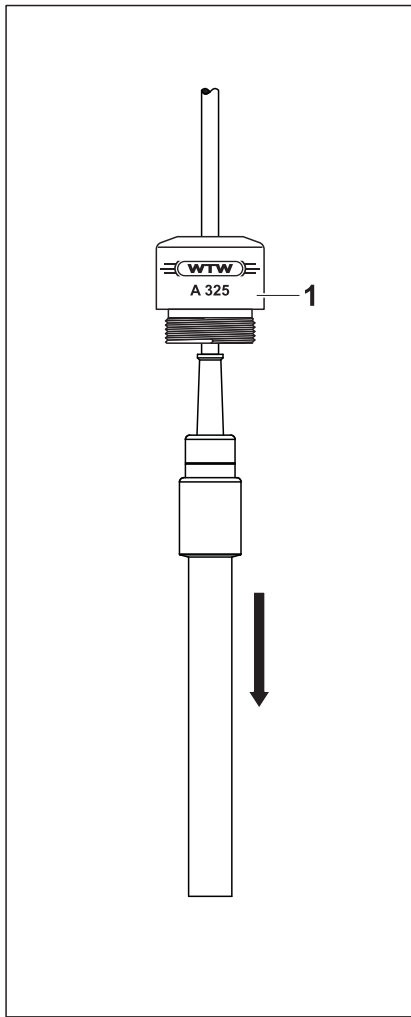

figure 1

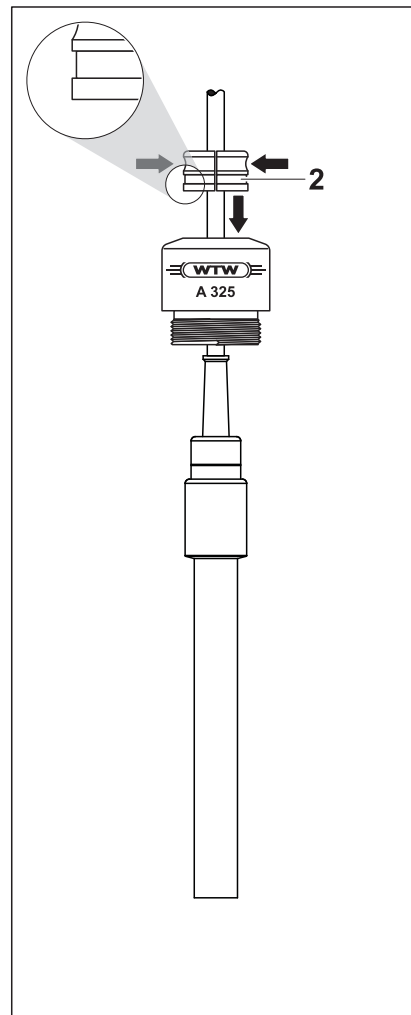

figure 2

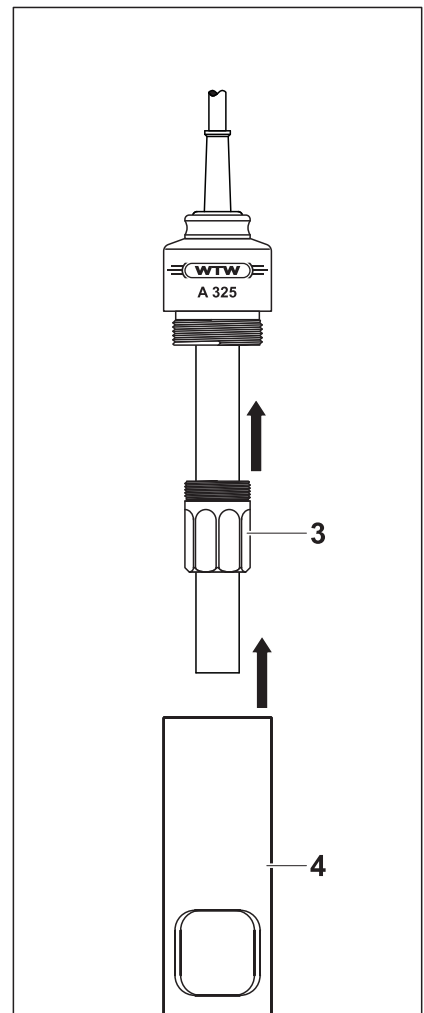

figure 3

Montage

Montage de la sonde

1	Pousser la sonde dans l'armature (pos. 1 fig. 1).
2	Passer la bague de serrage (pos. 2 fig. 2) dans le câble de sonde. Le bord à arête vive de la bague de serrage doit être dirigé vers l'armature (voir grossissement fig. 2).
3	Comprimer la bague de serrage au maximum (fente fermée), l'introduire dans l'armature et la faire s'enclencher en relâchant.
4	Repousser la sonde dans l'armature jusqu'à la butée (fig. 3).
5	Pousser l'écrou-raccord (pos. 3 fig. 3) sur la sonde et le visser à la main dans l'armature.
6	Visser la corbeille de protection par dessus (pos 4 fig. 3).

Caractéristiques techniques

Dimensions	Diamètre	38 mm
	Longueur (A 325/...)	200 mm
	Longueur (A 925/...)	228 mm
Matières	Armature	POM
	Bague de serrage	POM
	Corbeille de protection (A 325/K et A 925/K)	POM
	Corbeille de protection (A 325/S et A 925/S)	Acier spécial 1.4571
	Joint torique d'étanchéité (seulement A 325/...)	NBR

Autres accessoires

Description	Modèle	Référence
Couvercle de protection pour A 325/... et A 925/...	SK-325	201 580

INSTRUCCIONES DE MONTAJE

ba75827s02 12/2017



A 325/K

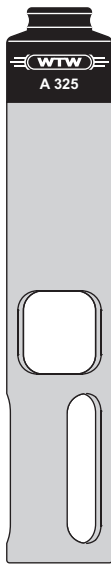

A 325/S



A 925/K

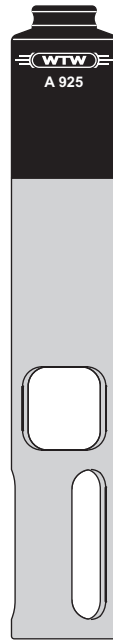

A 925/S

A 325/K, A 325/S
A 925/K, A 925/S



a xylem brand



Figura 1



Figura 2

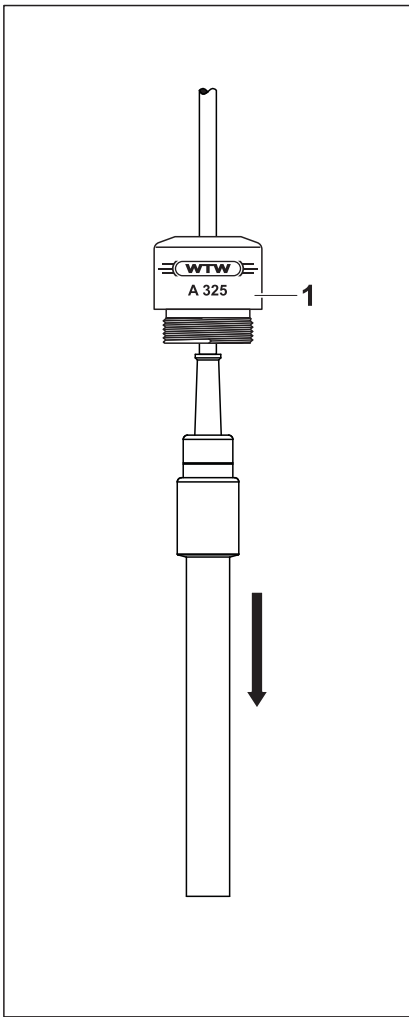

Figura 3

Montaje

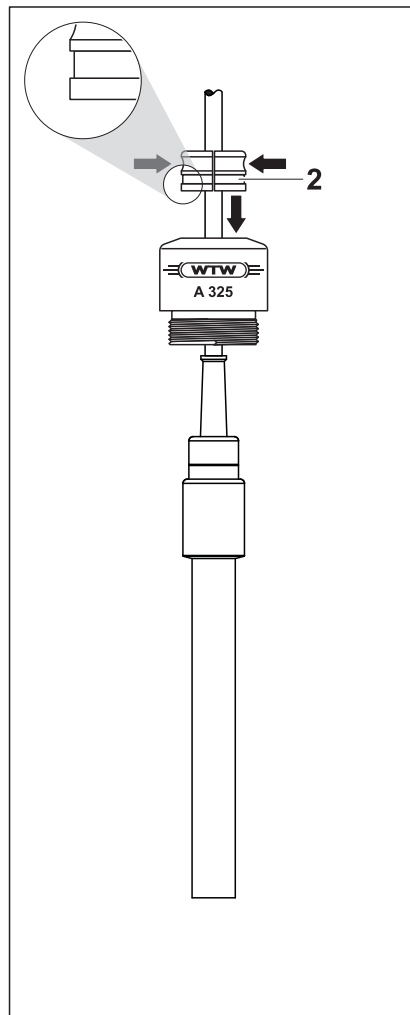
Instalación del sensor	1	Desplazar el sensor por el accesorio (pos. 1 en la figura 1).
	2	Colocar el anillo tensor (pos. 2 en la figura 2) en el cable del sensor. El borde agudo del anillo tensor debe quedar ubicado hacia el refuerzo de protección (vea el detalle en la figura 2).
	3	Oprimir el anillo tensor completamente (fisura cerrada), introducirlo en el refuerzo de protección y soltarlo para que encaje.
	4	Desplazar el sensor en el refuerzo de protección hacia atrás hasta el tope (figura 3).
	5	Desplazar la tuerca tapón (pos. 3 en la figura 3) por encima del sensor y atornillarla a mano en el refuerzo de protección.
	6	Atornillar el canastillo de protección (pos. 4 en la figura 3).

Especificaciones técnicas

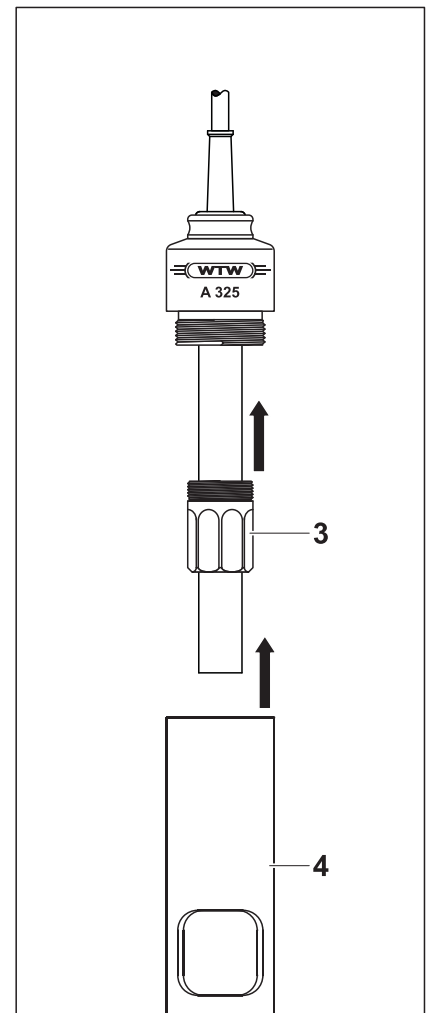
Dimensiones	Diámetro	38 mm
	Longitud (A 325/...)	200 mm
	Longitud (A 925/...)	228 mm
Materiales	Refuerzo de protección	POM
	Anillo tensor	POM
	Canastillo de protección (A 325/K y A 925/K)	POM
	Canastillo de protección (A 325/S y A 925/S)	Acero inoxidable 1.4571
	Anillos O (sólo A 325/...)	NBR

Otros accesorios

Descripción del funcionamiento	Modelo No.:	No. de pedido
Tapas de protección para A 325/... y A 925/...	SK-325	201 580

Xylem |'zīləm|

- 1) The tissue in plants that brings water upward from the roots;
- 2) a leading global water technology company.

We're a global team unified in a common purpose: creating advanced technology solutions to the world's water challenges. Developing new technologies that will improve the way water is used, conserved, and re-used in the future is central to our work. Our products and services move, treat, analyze, monitor and return water to the environment, in public utility, industrial, residential and commercial building services settings. Xylem also provides a leading portfolio of smart metering, network technologies and advanced analytics solutions for water, electric and gas utilities. In more than 150 countries, we have strong, long-standing relationships with customers who know us for our powerful combination of leading product brands and applications expertise with a strong focus on developing comprehensive, sustainable solutions.

For more information on how Xylem can help you, go to www.xylem.com.



Service and Returns:

Xylem Analytics Germany
Sales GmbH & Co. KG
WTW
Am Achalaich 11
82362 Weilheim
Germany

Tel.: +49 881 183-325
Fax: +49 881 183-414
E-Mail wtw.rma@xylem.com
Internet: www.xylemanalytics.com



Xylem Analytics Germany GmbH
Am Achalaich 11
82362 Weilheim
Germany

